



Slim Sectional OVERHEAD DOOR

Recommended Specifications

The sectional overhead "PIRIE SLIM SECTIONAL" shall be manufactured to comply with Pirie Enterprises Pty Ltd quality assurance programme. Individual sections shall be made from .55mm colour bond. All individual sections shall be of equal heights which will be calculated from the individual opening height. Individual sections shall have a down turned internal flange on top and bottom of each section to allow for weather proofing and interlocking. Three individual sections shall make one door panel. Sections shall be joined by a crimp/curling machine at spacings no greater than 420mm. Panel end muntins will be made for each door individually from 1.2mm zincanneal. A second flush end muntin will be folded from 1.2mm zincanneal and fitted at a spacing not greater than 1500mm apart. Panel height to be no higher than 650mm. Reinforcing brace to be fitted to top of each panel if required. Top panel to have extra muntin in centre for operator drive arm. An extruded weather seal is fitted to bottom panel only.

The door shall consist of panels hinged together to negotiate the curve of the track and a fixed matching head panel if required. The number of panels in each door shall be as recommended by the manufacturer. Each panel shall be fitted with rollers running in the side tracks. The side tracks shall guide the door movement so that the door can be raised clear of the opening to a horizontal position. Tracks, hardware and hinges hangers shall be made from galvanised or zincannealed steel. Hinges, hangers shall be fabricated from 2mm thick sheet. Tracks shall be fabricated from 1.6mm sheet and shall be curved where necessary to required radius and mounted on mild steel brackets fixed to the building structure by approved means. Horizontal runs shall be reinforced with mild steel angles. Springs shall be helical wound torsion springs mounted on a 25mm torsion bar with alloy cable drums attached. Galvanized lifting cables to be used. For wind specification contact manufacturer.

FOR FURTHER INFORMATION CONTACT MANUFACTURERS

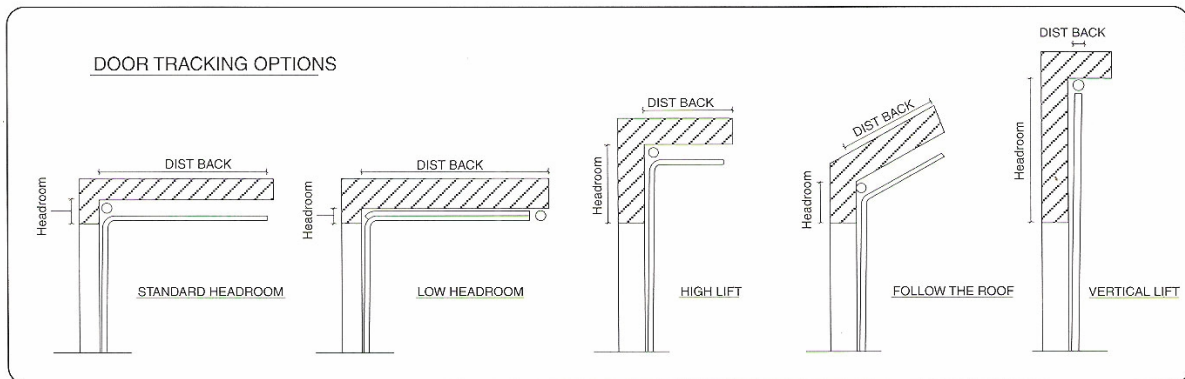
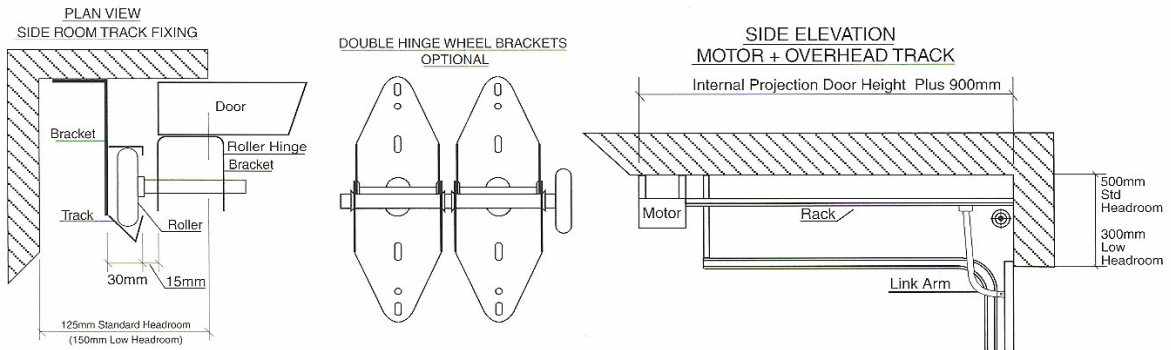

Other products available: Manufacturers of Industrial, Commercial, Domestic Automatic Doors and Gates • Structural Aluminium
• Architecturally designed Sectional Overhead Doors • Aluminium Louvres & Vents • Glass bricks Pre Fab or Fire Rated • Fire Doors • Parking Systems



Showroom: 22 Industrial Avenue, Southport 4215
 Phone: 07 5539 6644
 Fax: 07 5539 6988
 A.B.N. 16 009 731 113

AGENT:-